

ARB NISSAN GU PATROL REAR STEP TOW BAR

Product number: 5617210/20

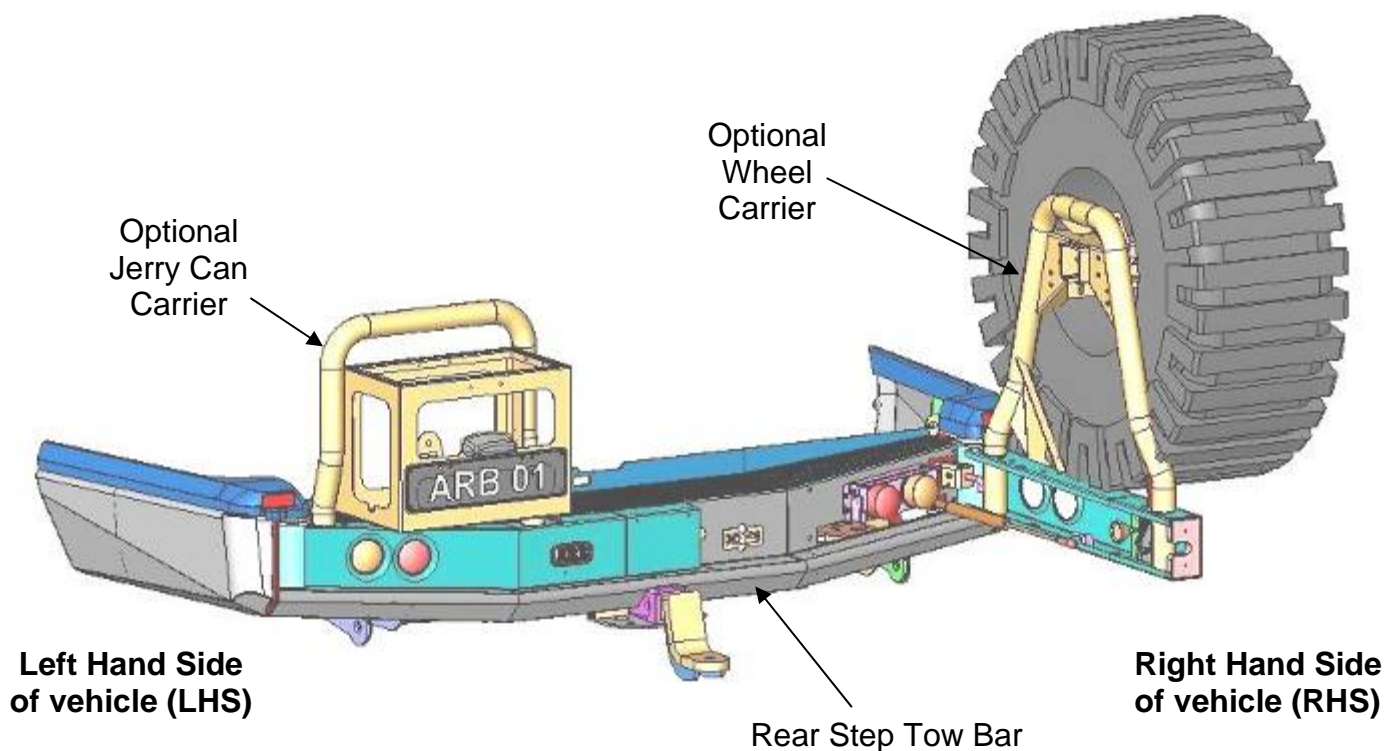

**READ FITTING INSTRUCTIONS
CAREFULLY BEFORE PROCEEDING**

USE	PART No	QTY	DESCRIPTION
FIT TAIL LIGHT ASSEMBLIES TO REAR BAR	6821172L	1	Tail Light Assembly – LHS
	6821172R	1	Tail Light Assembly – RHS
	6151017	12	Bolt M6 x 16
	6151128	8	Nut M6 flange
	6151300	4	Nut M6 caged
	6151046	12	Washer 6mm flat
	3756681	2	Light mount cover bracket
FIT CAGED NUTS TO REAR BAR	6151300	12	Nut M6 caged
	6151303	4	Nut M8 caged
FIT LOCKING PIN BRACKETS TO REAR BAR	3756702	2	Locking pin bracket
	6151022	4	Bolt M8 x 25
	6151132	4	Nut M8 flange
	4581044	4	Washer 8mm flat
CHASSIS NUT CHANNEL ASSEMBLY	4601063	2	Nut channel
	6151306	6	Nut M12 caged
FIT CAGED NUTS TO CROSSMEMBER PLATES	3199751	2	Crossmember nut plate
	6151302	2	Nut M10 caged
FIT BAR TO REAR CROSS MEMBER AND WHEEL CARRIER LOCATOR BRACKET IF REQUIRED	6151095	6	Bolt M12 x 35 x 1.25
	4581049	8	Washer 12mm flat
	6151135	2	Nut M12 x 1.25
	4581050	6	Washer 12mm spring
FIT BAR TO UNDERSIDE OF CHASSIS	6151340	8	Bolt M12 x 50 x 1.75
	4581007	10	Washer ½" flat heavy duty gold zinc
	4581050	8	Washer 12mm spring
	6250004	2	Chassis packer
	6151189	2	Nut M12 x 1.75
FIT BAR TO CROSSMEMBER	5848305	2	Crossmember packer
	6151204	2	Bolt M10 x 35
	4581040	2	Washer 10mm flat
	4581048	2	Washer 10mm spring
FIT BAR TO CHASSIS SIDE	6151099	4	Bolt M14 x 40
	4584298	4	Washer flat 14mm
	4581052	4	Washer 14mm spring
FIT LOOM TO BAR	6821164	1	Loom
FIT CENTRE COVER PANEL	6522647	1	Centre cover panel
	6151300	2	Nut M6 caged
	6151352	2	Socket head cap screw M6 x 25 stainless steel
	6151207	2	Bolt M6 x 25
	6151046	4	Washer 6mm flat
	4581036	4	Washer 6mm spring
	5848302	2	Packer black nylon
	6250003	2	Spacer 8mm thick gold zinc

FIT END SURROUNDS TO REAR BAR	3131186L	1	End surround LHS
	3131186R	1	End surround RHS
	6151083	6	Bolt M8 x 35
	6151132	6	Nut M8 flange
	4581044	6	Washer 8mm flat
	6250003	6	Spacer 8mm thick gold zinc
FIT END SURROUND BRACES	3756700L	1	End surround brace LHS
	3756700R	1	End surround brace RHS
	6151022	8	Bolt M8 x 25
	6151132	8	Nut M8 flange
	4581044	8	Washer 8mm flat
FIT URETHANE TRIMS	3162478L	1	Vertical trim LHS
	3162478R	1	Vertical trim RHS
	3162480L	1	End surround trim LHS (to suit model pre 10/04)
	3162480R	1	End surround trim RHS (to suit model pre 10/04)
	3162481L	1	End surround trim LHS (to suit model 10/04 on)
	3162481R	1	End surround trim RHS (to suit model 10/04 on)
	6821166	2	Reflector
	6151162	10	Nut M6 nyloc
	4581082	10	Washer 6mm flat heavy duty black zinc
FIT MUDFLAPS	6151017	6	Bolt M6 x 16
	6151128	6	Nut M6 flange
	4581082	6	Washer 6mm flat heavy duty black zinc
FIT TOP INFILL PLATE	3199749	1	Top Infill Plate
	3199750	1	Aluminium Step Plate
	4590019	2	Rubber Extrusion Seal
	6151256	8	Button Head Cap Screw M6 x 16 stainless steel
	6151128	2	Flange Nut M6
FIT GOOSENECK	4761132	1	Gooseneck
	55010	1	Pull pin
	55020	1	Spring Clip
FIT TRAILER PLUG	6151370	2	Screw M5 plastite pan head

PARTS SUPPLIED WITH THIS KIT TO BE USED WHEN FITTING WHEEL CARRIERS OR JERRY CAN CARRIERS

FIT NUMBER PLATE LIGHT	86060BL	1	Number plate light
	6151281	2	Screw M5 pan head
	6151282	2	Nut M5 flange
FIT CENTRE LOCATOR	3756677	1	Centre locator bracket

TOOLS REQUIRED: Basic tool kit, 30mm socket, ¼" drive socket set, silicon, angle grinder.

TORQUE SETTINGS: 6mm – 9Nm, 8mm – 22Nm, 10mm – 44Nm, 12mm – 77Nm, 14mm – 100Nm

FITTING TAIL LIGHTS TO BAR

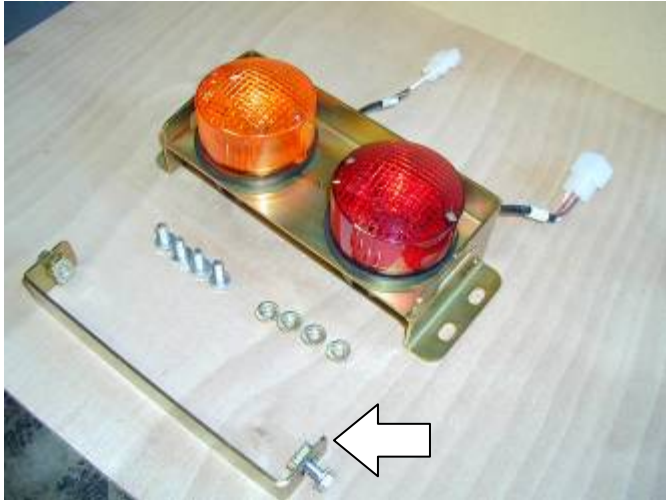

1. Compile components as shown.
 - Light assembly (LHS shown)
 - Light cover
 - 6 x M6 x 16mm bolts
 - 6 x M6 flange nuts
 - 2x M6 cage nuts
 - 6 washers to suit M6
2. Fit cage nuts to light cover as shown.

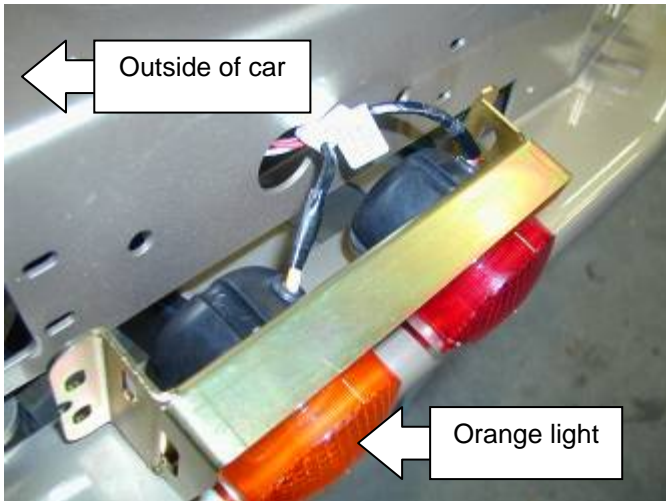

When fitting light assemblies to bar, orange (indicator) lights must be to the outside as shown. The flange on the bracket should also be at the top.

3. Feed looms through large hole in bar.



4. Fit light assemblies using M6 hardware. Finger tighten only.
5. Repeat steps 1 to 3 for RHS assembly.



6. Fit M6 cage nuts to light mount cover bracket as shown below.
7. Using **M6 x 16 bolts** and flat washers, fit cover bracket to light mount.



FITTING CAGE NUTS TO BAR



8. Fit M6 cage nuts (12 total) in square holes in top and front of bar as shown.



9. Fit M8 cage nuts to square holes on both left and right hand sides of the rear bar as shown.

FITTING LOCKING PIN BRACKETS TO BAR

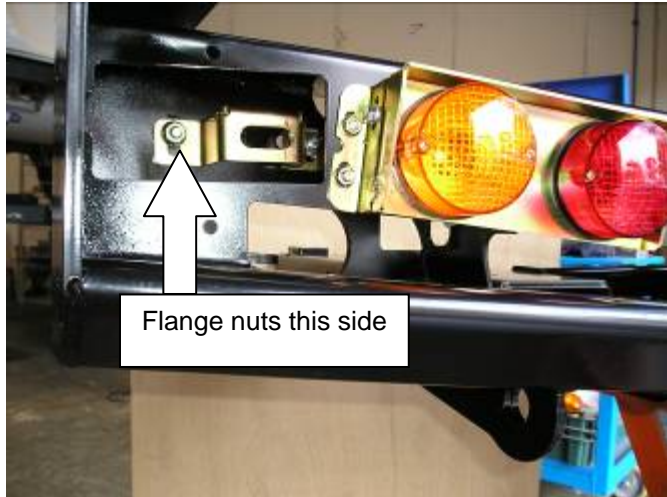

10. Fit locking pin brackets using **M8 x 25 bolts**, flat washers and flange nuts. Finger tighten only.

11. (Viewed from front of bar LHS.)

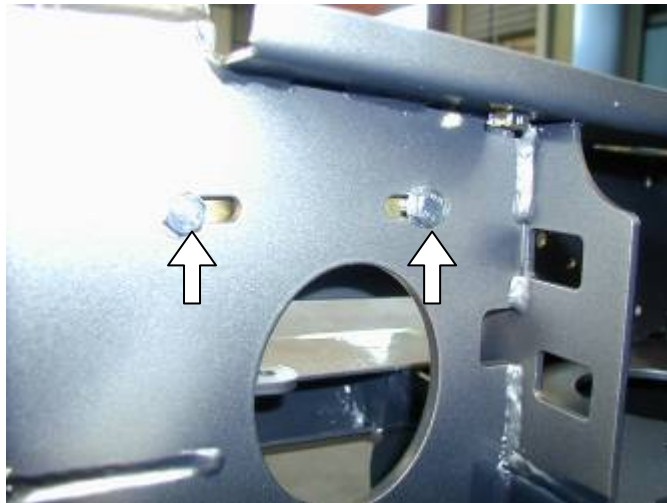

M8 bolts must fit in rear of bar for ease of adjustment later on.

(Viewed from rear of bar LHS.)



12. If a wheel carrier or jerry can carrier is not to be fitted a cover panel must be fitted.

If cover panels are to be fitted they must be fitted to the bar before it is fitted to the vehicle.

Refer to fitting instructions supplied in cover panel fitting kit for fitment of cover panel.

PREPARING VEHICLE FOR REAR BAR

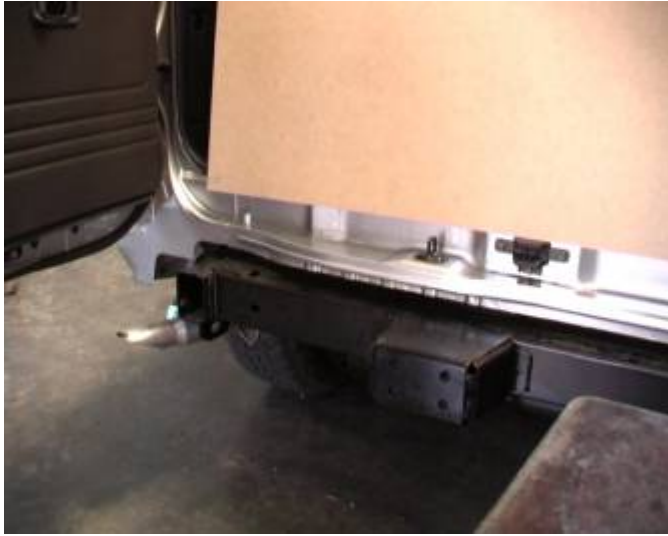

13. To fit Rear Bar to vehicle, remove bumper bar, mudflaps and tow bar (if fitted) from vehicle.
14. If your GU Patrol is fitted with a welded centre tow mount bracket, the bracket must be removed to allow for bar fitment.



15. Cut bracket from rear crossmember as shown.



16. Ensure crossmember front and top faces are free of all welds so rear bar can sit hard against crossmember.
17. Paint crossmember black.

FITTING REAR BAR TO VEHICLE



18. To fit Rear Bar to vehicle, remove bumper bar, mudflaps and tow bar (if fitted) from vehicle.

19. OPTIONAL

20. Paint lower rear quarter panel satin black



21. Fit **M12 x 1.75 cage nuts** to channel and insert into ends of chassis rails.

Note notch in channel must be towards rear of vehicle.



22. Hammer out tie down plates to allow for bar fitment.



23. Fit M10 caged nuts to crossmember nut plates.
Make 1 pair – 1 LHS and 1 RHS as shown.



24. Fit nut plates into crossmember from behind.
The offset caged nut must be fitted so that nut is towards the rear of the crossmember.
25. Using a screwdriver, align nut with hole in crossmember.



26. With the help of a friend fit bar to vehicle.
(Rear bar shown with LHS cover panel fitted.)



27. Use four **M12 x 35 x 1.25 bolts**, spring washers and flat washers to fit rear bar to rear crossmember.

Secure finger tight only. If fitting a swing away wheel carrier to vehicle, use the two remaining 12mm x 35 mm x 1.25 bolts etc to bolt the locator bracket to front of rear bar.



28. Fit three **M12 x 50 x 1.75 bolts**, spring washers and large gold flat washers to underside of chassis bracket.

Secure finger tight only.

29. Fit **M12 x 50 x 1.75 bolts** through vehicle tie down points and secure using a large gold flat washer on each side and a spring washer on the nut side.

Secure finger tight only.



30. Insert spacer between rear bar and vehicle crossmember as shown. Align hole with nut plate previously inserted in crossmember.



31. From underside of rear bar, fit **M10 x 35 bolt**, spring washer and flat washer to caged nut plate in crossmember.
Secure finger tight only.

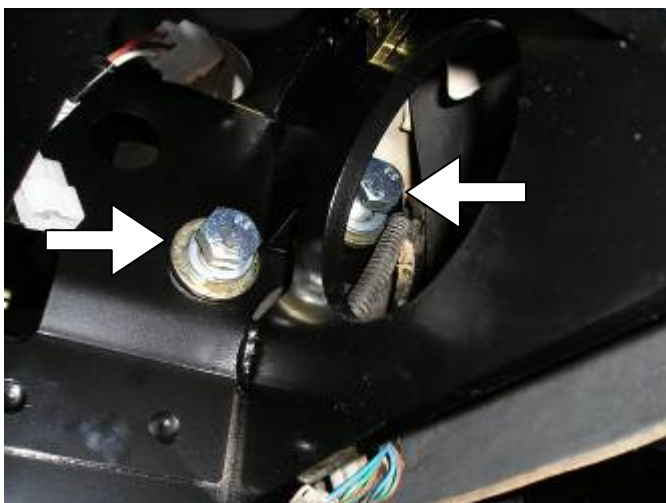

32. Use two **M14 x 40 bolt**, spring washer and large gold flat washer to secure rear bar side plate to side of chassis. (RHS shown)
Secure finger tight only.



33. Tighten only M12 bolts from underside of chassis.



34. Take a measurement from the top of rear bar to underside of tail light to check if rear bar is level.



35. If not level, remove bolts from the side that is too high and insert a spacer plate between the chassis bracket and the chassis. (LHS shown)

36. Replace bolts, tighten and recheck if the bar is level.

This process may need to be repeated until bar is level.

37. When level tighten all bolts fitted in steps 27 – 32 securely.

FITTING LOOM TO REAR BAR



38. Feed loom through centre section of rear bar to outer ends of bar, through holes in top of side plates and connect to tail light assemblies and vehicle loom.

Green indicator wire of loom fits to RHS of vehicle, and yellow indicator wire to LHS.

39. Cable tie loom clear of any moving parts.

AT THIS STAGE JERRY CAN CARRIERS OR WHEEL CARRIERS MUST BE FITTED.

TO FIT JERRY CAN CARRIERS AND WHEEL CARRIERS, REFER TO FITTING INSTRUCTIONS SUPPLIED IN FITTING KITS WITH JERRY CAN CARRIERS OR WHEEL CARRIERS.

IF A JERRY CAN CARRIER OR WHEEL CARRIER IS NOT TO BE FITTED, THE COVER PANEL SHOULD BE ALREADY FITTED. (REFER TO STEP 12.)

FITTING CENTRE COVER PANEL



40. Compile the components as shown

- Centre cover panel
- 2 x M6 cage nuts
- 2 x M6 x 25 socket head cap screw stainless steel
- 2 x M6 x 25 bolts
- 4 x 6mm flat washers
- 2 x black nylon spacers
- 2 x 8mm thick gold zinc spacers
- 4 x 6mm spring washers

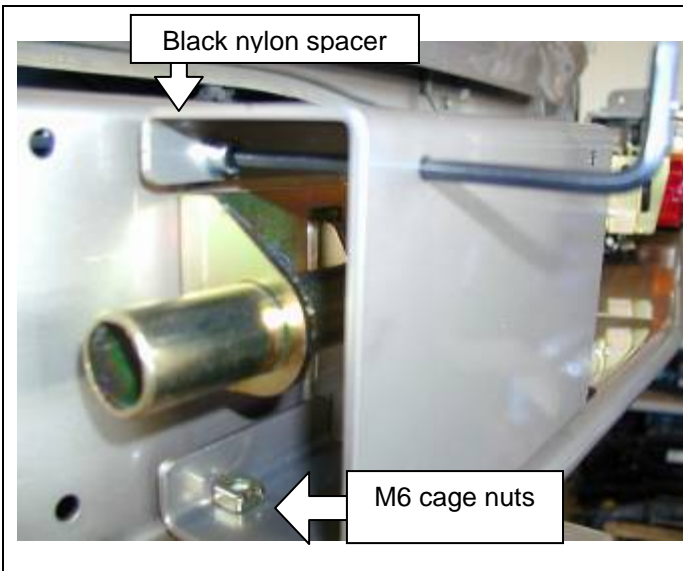

41. Place M6 cage nuts into lower section of centre cover panel.
42. Fit two **M6 x 25 stainless steel socket head cap screws**, spring washers and flat washers through top flange inside cover panel as shown.
43. Place black nylon spacers on screws on outside of centre cover panel flange and attach to captive nuts in rear bar.
(Finger tighten only.)



44. Place 8mm gold spacer between underside of centre cover panel and rear bar.

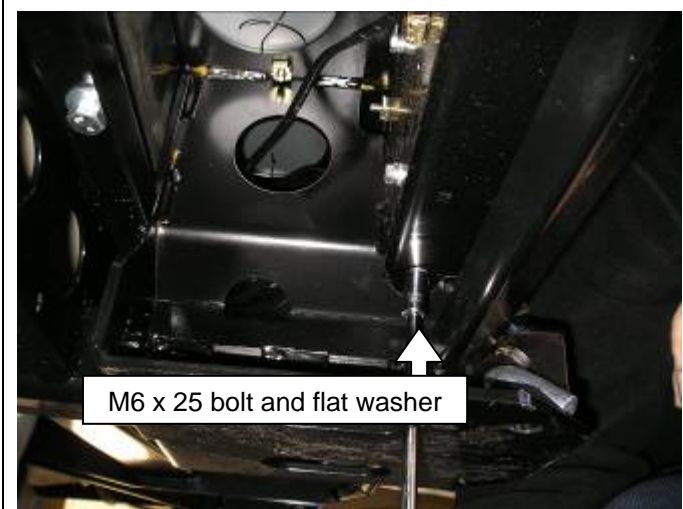

45. From underneath rear bar pass two **M6 x 25 bolts**, spring washers and flat washers through the aligned parts and finger tighten.

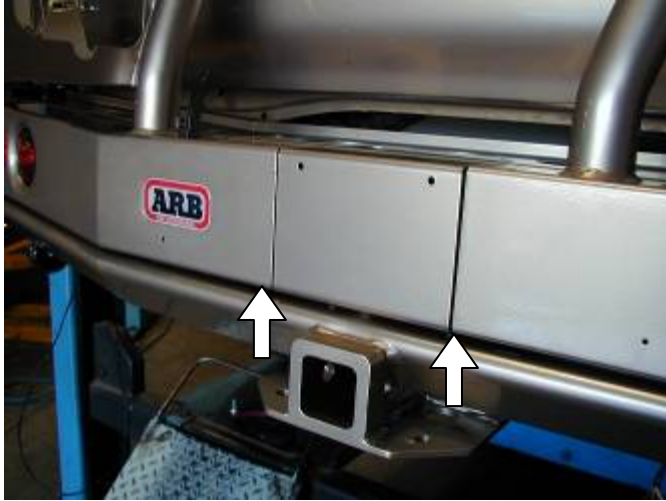

46. Align faces of centre cover panel with wheel carrier, jerry can carrier or cover panel and tighten securely.

FITTING END SURROUNDS TO REAR BAR

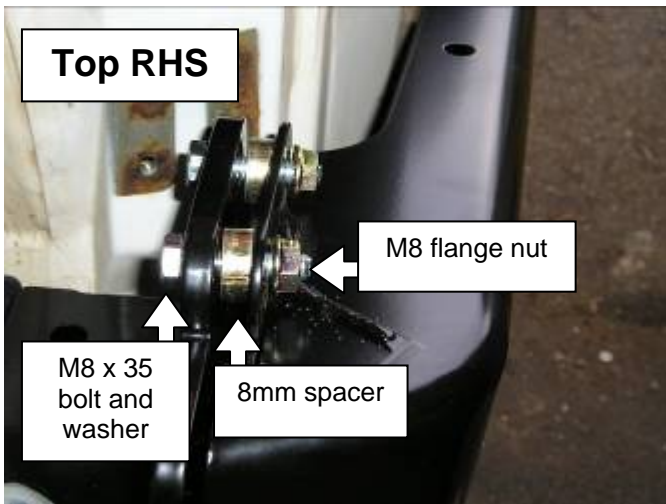

47. The surrounds are attached to rear bar using three **M8 x 35 bolts**, flat washers and flange nuts per side.

48. Place bolts and flat washers through the top two holes of the rear bar end plate as shown.

49. Fit 8mm gold spacer to bolts, then fit end surround and secure finger tight with M8 flange nuts.

50. Fit the lower bolt with washer, spacer and nut in the same sequence as the upper two.
Secure finger tight only.



51. Using two **M8 x 25 bolts**, flat washers and flange nuts fit end surround braces to vehicle chassis. (RHS shown.)

Secure finger tight only.



52. Using **M8 x 25 bolts**, flat washers and flange nuts secure end surrounds to braces finger tight. (RHS shown.)
Secure finger tight only.



53. Before tightening bolts fit urethane vertical trim between end plate and end surround.
54. Adjust trim to fit snugly around the rear bar and the end surround.



55. Align top face of end surround parallel with body of vehicle.
56. Starting in the top corner of the end surround and working backwards, tighten all bolts.

A second person may be required to help keep the vertical trim fitting snugly and to ensure the end surround remains parallel to the body.



57. Fit urethane buffer to top of end surround using M6 nyloc nuts and large black flat washers.

When fitting washers to studs under end surround smear flat washers with grease to hold them in place as shown below.

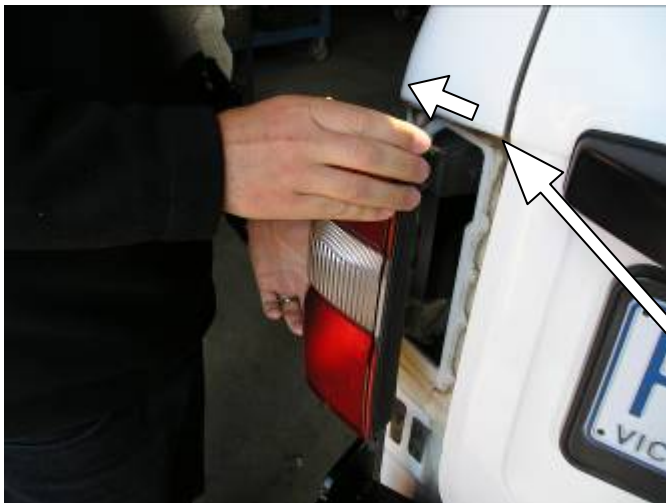

58. If it is difficult to position buffer under taillight while fitting to rear bar end surround, remove tail light as described below.

59. Remove trim flap from inside vehicle.



60. Remove two screws securing tail light.

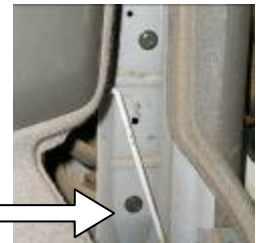
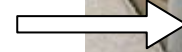



61. Gently pull light assembly sideways as shown.

62. Fit buffer to end surround then refit taillight.



63. Fit reflector to buffer. Fit top edge in first and pivot downwards. Press in firmly.

FITTING MUDFLAPS

	<p>64. Fit mudflap using two original holes as indicated by arrows.</p> <p>65. Using three M6 x 16 bolts, flat washers and flange nuts per side, fit mudflap to vehicle.</p> <p>66. To secure top of mudflap, drill hole in mudflap and end surround of rear bar.</p> 
---	--

FITTING TOP INFILL PLATE, ALUMINIUM STEP PLATE AND TRAILER PLUG

	<p>67. Using M6 button head cap screws & M6 flange nuts, fit top infill plate.</p>
	<p>68. To fit rubber sealing strip to underside of front and rear of aluminium step plate, lay strips on the underside of step plate and place so over hang is even on both ends. Using scissors, cut darts up to the bulb end of the rubber strip, so the strips can follow the front and rear profile of the aluminium step plate.</p>

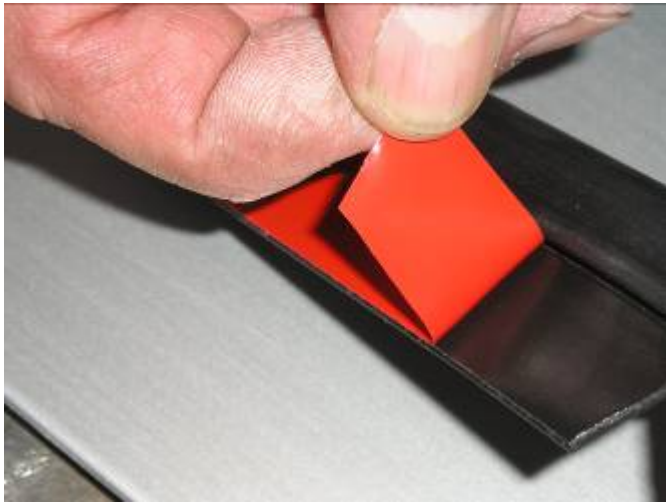

69. Carefully remove backing tape on the rubber strip and fit to step plate working from the centre outwards. Make sure rubber strip hugs the front and rear edge of the aluminium step plate.

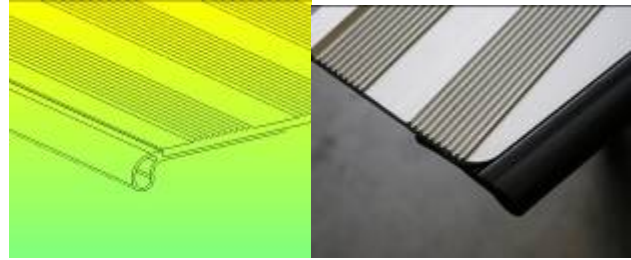

70. Using **M6 button head cap screws** fit aluminium step plate.

It is recommended to use **silicon** under both plates to avoid vibration.

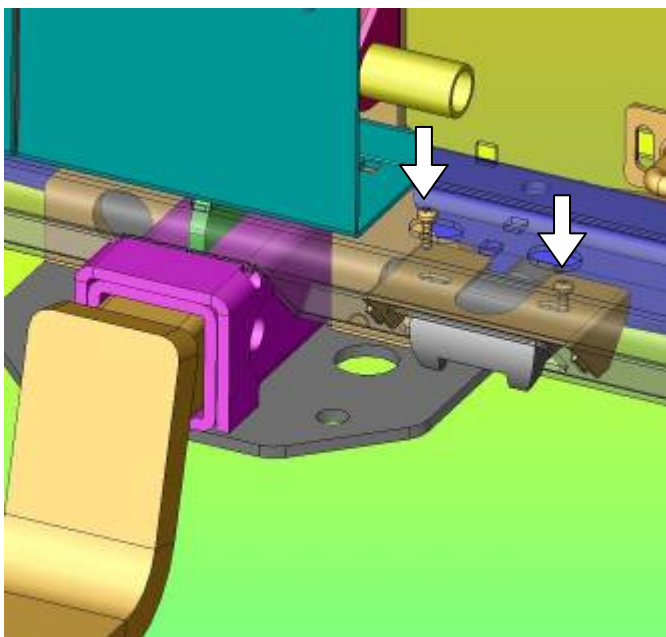

71. Fit trailer plug to recess using M5 pan head screws as shown by arrows.

For aesthetics and protection of the plug it is recommended that a flat type plug is fitted.

To fit alternate plugs an adaptor bracket (part number 5700090) is available. This is not supplied as standard with the rear bar kit.



72. Fit gooseneck with pull pin and spring clip as shown.

