



RHINO-RACK

NM-NP Pajero Rhino Heavy Duty - Two Bar Trackmount System

Important: Please read these instructions carefully prior to installation. Please refer to your fitting instruction to ensure that the roof racks are installed in the correct locations. Check the contents of kit before commencing fitment and report any discrepancies. Place these instructions in the vehicle's glove box after installation is complete.

Parts List **Maximum carrying capacity: 100kg**

Item.	Description.	Qty.	Part.
1	Track End Cap (left)	2	C393
2	Pajero Track 1950mm	1 pair	A273
3	Track Mount End Cap (right)	2	C394
4	Heavy Duty Rubber 1375mm	2	R004
5	Heavy Duty Crossbar End Cap	4	M002
6	Heavy Duty Crossbar 1375mm	2	A020
7	M6 x 35 Button Security Screw	8	B092
8	M6 Spring Washer	8	W004
9	M6 x 12.5mm Flat Washer	8	W003
10	RLTP Track Mount Leg	4	M010
11	M6 x 21.43mm x 4.40mm Brass Nut	8	N009
12	M10 Channel Nut	4	N024
13	M10 x 38mm Flat Washer	4	W022
14	M10 Internal Shakeproof Washer	4	W021
15	M10 x 25mm Hex Bolt	4	B071
16	Rivet	19	H005
17	5mm Security Allen Key	1	SECKEY-S
18	Butyl Patches	20	CA1397
19	Instructions	1	RR127

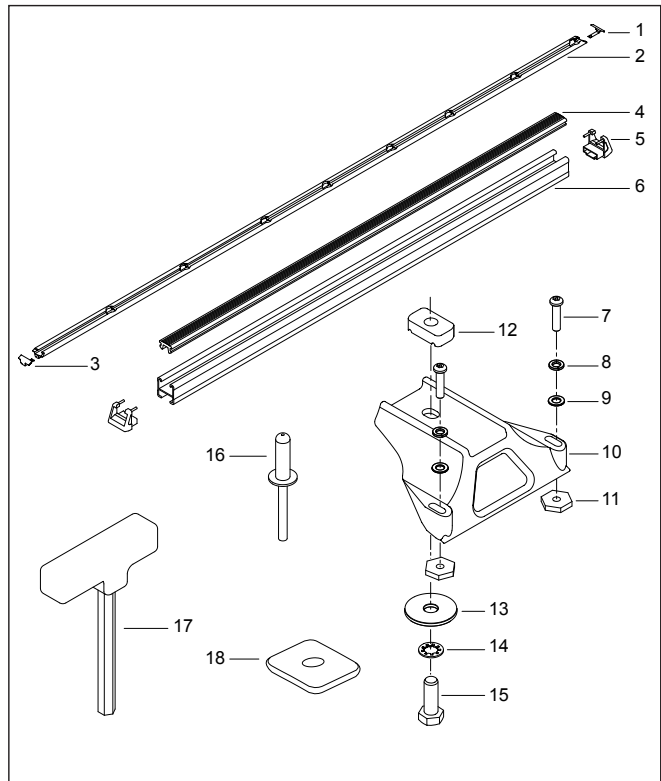

- Tools Required:**
- Pneumatic or concertina type rivet gun
 - Power or Cordless drill
 - Vacuum cleaner
 - Selleys Butyl Mastic
 - 5/8 or 16mm spanner or socket wrench
 - Hacksaw
 - Marking pen
 - 5mm drill bit with 5mm depth stop
 - Cold galvanizing solution & brush
 - 5mm Security Allen key, provided in kit
 - Measuring tape

Care Instruction:
Clean vehicle roof prior to fitting Rhino Heavy Duty roof racks.

1 Removal of roof trim. Grip rubber trim with fingers and carefully lift to expose the white plastic clips. Careful not to scratch the paint, slide clips sideways to unhook them from the roof channel, may need to

LIFT TRIM FROM EDGE FACING TOWARDS CENTRE OF ROOF.

2 Once trim is removed clean out roof channel thoroughly before placing track in place. Roof Tracks are LEFT & RIGHT handed.

LEFT Track
Front of Vehicle

3 Align the track as shown, locating the track over the three hooks in the roof channel.

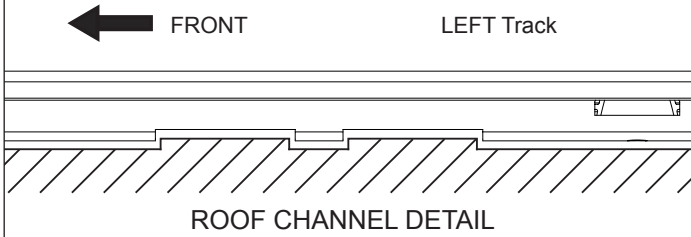

4 Hold track down in the roof channel. Make sure the LEFT and RIGHT track ends are parallel. Mark all holes with a marking pen. Remove the track.

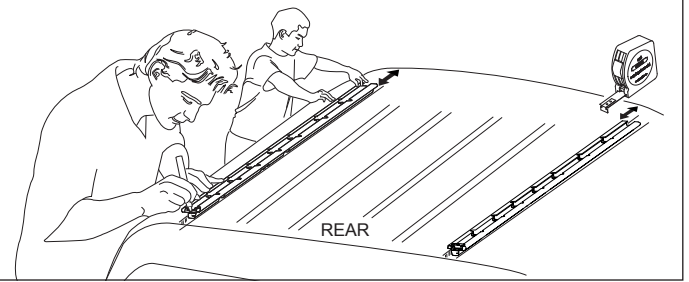

5 Accurately centre punch all holes before drilling.



6 Drill through roof (there are 3 skins) using a 5mm drill bit and a drill stop set to a 5mm depth. Set the drill stop to ensure you don't drill through the roof lining. Using a drill stop will alleviate the need to remove the hood lining and also minimise the risk of damage to air conditioning pipes.

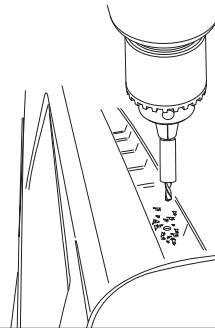

NOTE:

AIR CONDITIONING PIPES RUN ALONG THE INSIDE OF THE ROOF. USE CARE WHEN BREAKING THROUGH. A DRILL STOP IS RECOMMENDED.

7 Vacuum swarf from the roof channel to avoid scratching.

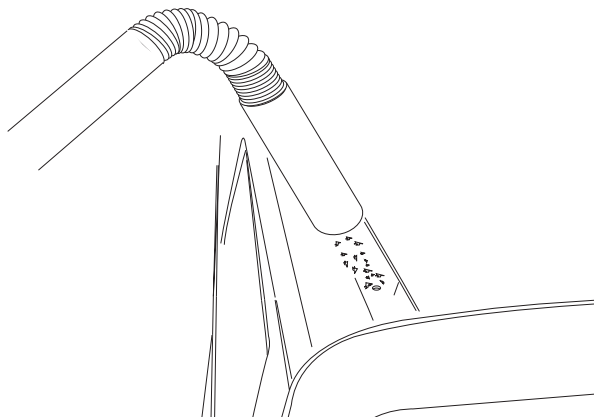

8 Apply a liberal amount of cold galvanizing solution to the inside and surrounds of all holes. Allow cold galvanizing solution to dry, three to four minutes, then apply a liberal amount of Selleys Butyl Mastic in and around each hole.

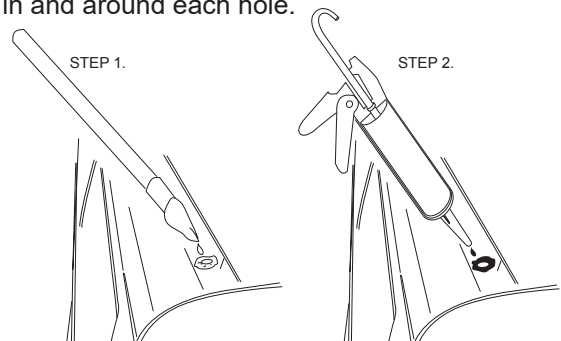

9 Because the track profile is asymmetrical there are two types of track end caps.

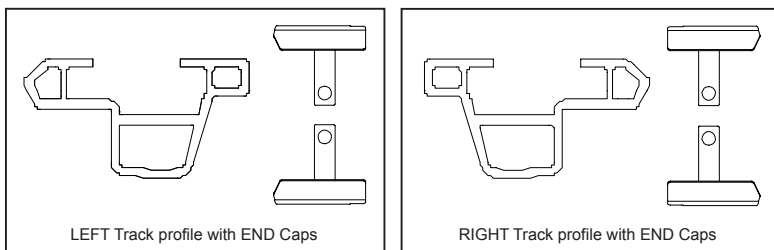

10 1: Remove the backing tape from the Butyl Patches. 2: Place over holes drilled. Once in place remove the rest of the protective tape from the top of the patches. This patch will provide the water tight seal.

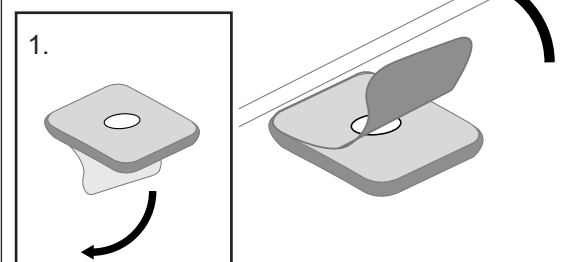

11 Peel the backing tape off the track. Accurately place the track over the drilled holes in the roof channel using the rivets to position. Leave the end rivet out until fitting the End Caps.

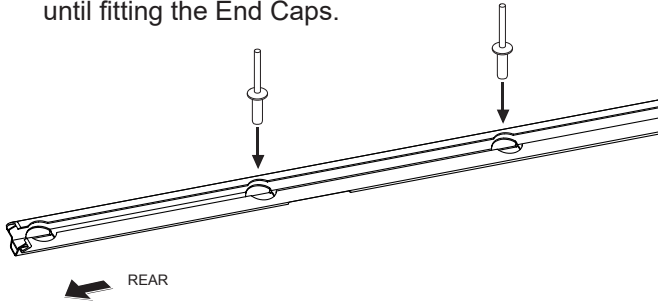

12 Slide the end cap into the correct track end. Make sure that the hole on the end cap lines up with the hole on the track before riveting in place.

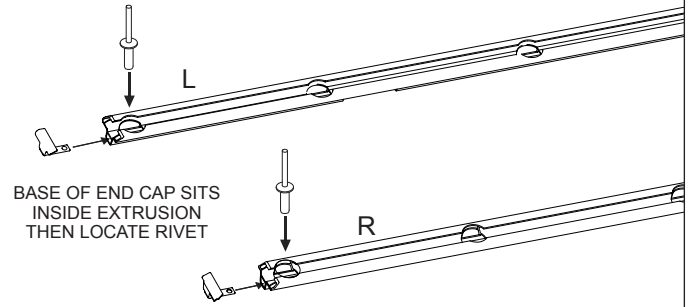

13 Using either a pneumatic or concertina type rivet gun, rivet track and end caps into place, making sure all rivets are seated firmly onto the base of the track.

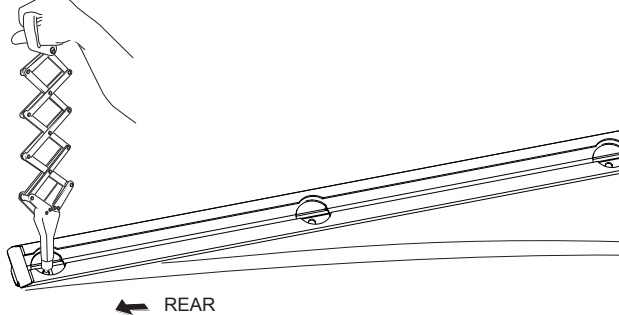

START AT REAR OF VEHICLE THEN WORK FORWARD, BECAUSE OF ROOF SLOPE.

14 The original roof trim will have to be measured and cut once the tracks are riveted in place. Make sure the front end of the trim sits correctly under the windscreen rubber before measuring and cutting. When cut (**using a Fine Tooth Hacksaw**) the roof trim must butt up against the Track End Cap.

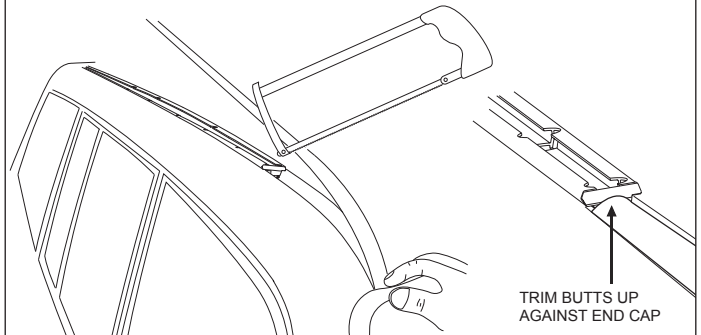

15 Unscrew the brass hex nuts from RLTP legs and slide them into the roof track channel. The legs will be fitted in place after the cross bars are attached.

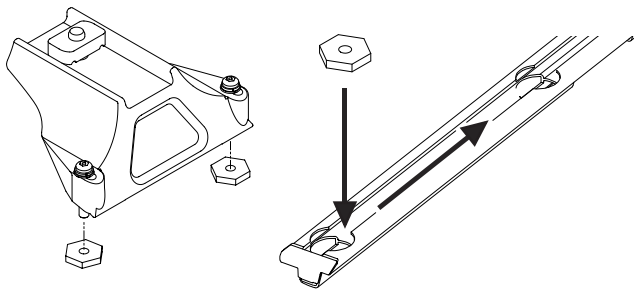

16 Slide the cross bar onto the leg and locate with the M10 channel nut. Leave untensioned at this stage.

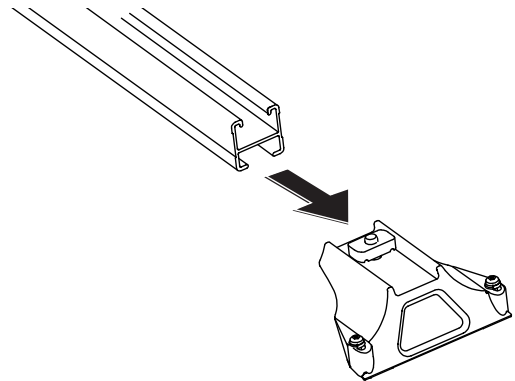

17 Finger tighten the leg attachment bolt so that the channel nut turns to locate across the cross bar. The legs will require adjustment later.

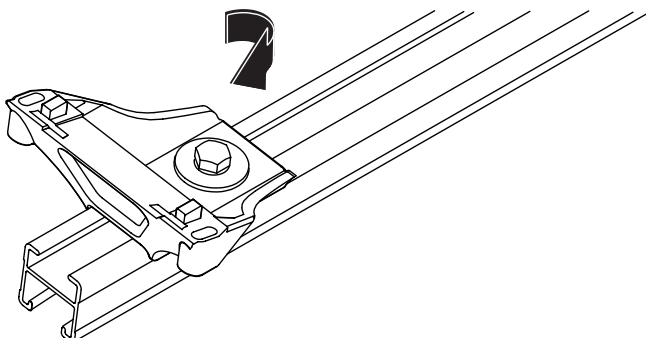

18 Check that the channel nut is fully located across the bar.

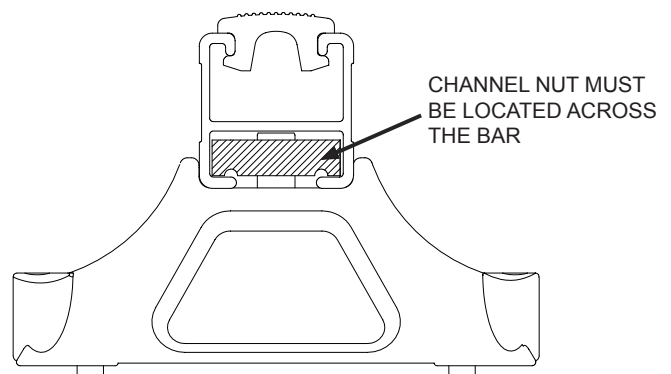

- 19** Locate the RLTP legs onto the tracks then screw M6 security screws into the brass hex nuts (3-4Nm). Leave loose for adjustment.

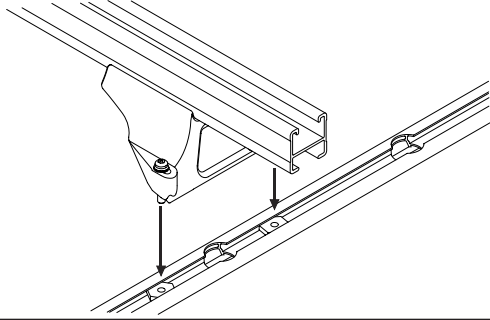

- 20** Tighten the cross bar attachment bolts. Recommended tightening torque (5Nm). Ensure that the channel nut is located across the cross bar.

**DO NOT
OVER TIGHTEN**

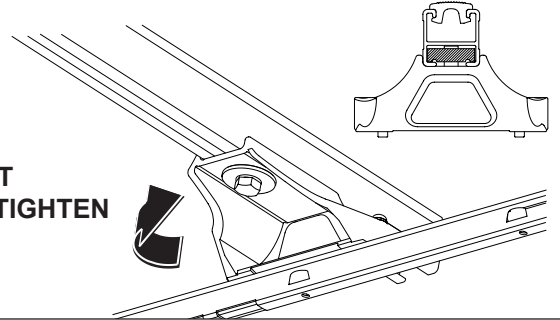

- 21** Check the cross bar over hang is equal on both sides, re-adjust if required.

EQUAL OVER HANG DISTANCE

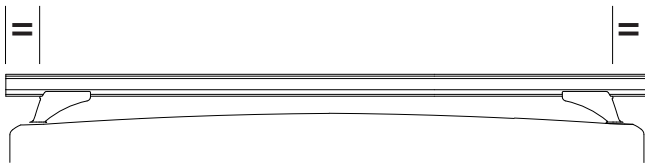

- 22** When front and rear cross bars are in required positions, tension RLTP legs and cross bars.

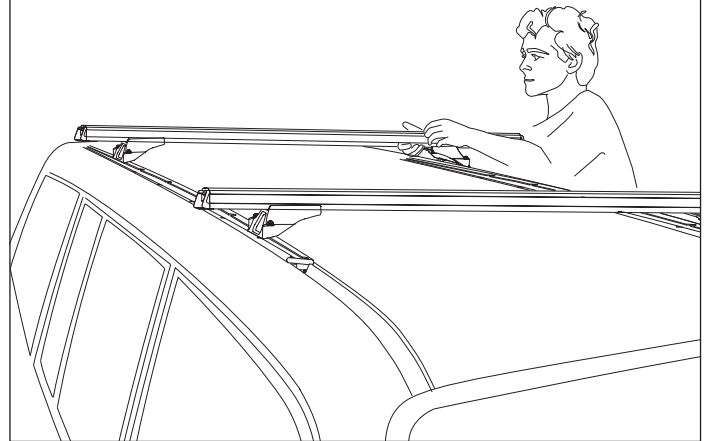

- 23** Insert the crossbar rubber buffer strips into the top of the crossbar. Insert the end caps into the ends of the crossbar, a rubber mallet may be required to fit the end caps.

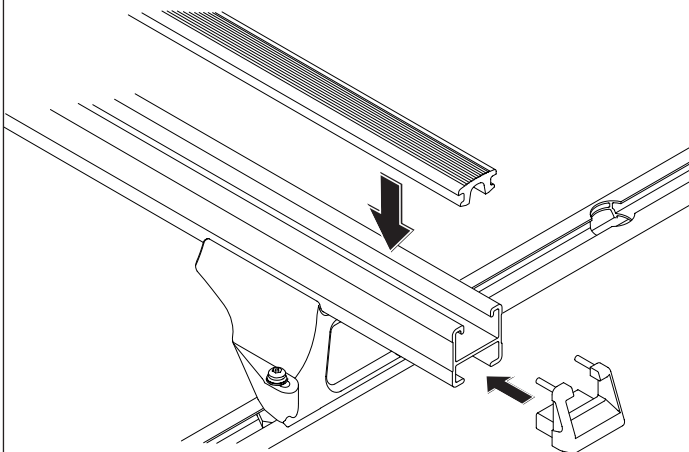

- 24** Note: When fitting a third crossbar, the following leg height spacers must be used to ensure all 3 crossbars are level.

REAR cross bar: LHSPAIR x 1
FRONT cross bar: LHS2PAIR x 1

Important Information

Maximum carrying capacity: 100kg

Recommendations:

It is essential that all bolt connections be checked after driving a short distance when you first install your cross bars.

Bolt connections should be checked again at regular intervals (probably once a week is enough, depending on road conditions, usage, loads and distances travelled). You should also check the cross bars each time they are refitted.

Make sure to fasten your load securely. Please ensure that all loads are evenly distributed and that the centre of gravity is kept as low as possible.

Use only non-stretch fastening ropes or straps.

Sensitivity to cross winds, behaviour in curves and braking:

The handling characteristics of the vehicle, changes when you transport a load on the roof. For safety reasons, we recommend you exercise extreme care when transporting wind-resisting loads; special consideration must be taken into account when braking.

Please remove cross bars when putting vehicle through an automatic car wash.

Load Ratings:

Maximum permissible load is 100kg per pair of roof racks (include the weight of the cross bars, 5kg). When roof racks are to be used in off-road conditions, please build a safety factor of 1.5 into this load limit. Although the roof racks are tested and approved to AS1235-2000, Australian road conditions can be much more rigorous. However, increasing the number of cross bars does not increase the vehicles maximum permissible roof loading.

Note for Dealers and Fitters.

It is your responsibility to ensure instructions are given to the end user or client

Rhino-Rack
3 Pike Street, Rydalmere,
NSW 2116, Australia.
(Ph) (02) 9638 4744
(Fax) (02) 9638 4822

Document No: RR-127
Prepared By: Craig Jones
Authorised By: Gary England

Issue No: 04
Issue Date: 31/08/2018

These instructions remain the property of Rhino-Rack Australia Pty. Ltd. and may not be used or changed for any other purpose than intended.